

NEMA Space-Savings Family of Contactors and Starters



Contents

Description

	<i>Page</i>
Contactors and Starters	
Catalog Number Selection	V5-T2-64
Product Selection	V5-T2-64
Accessories	V5-T2-66
Renewal Parts	V5-T2-70
Technical Data and Specifications	V5-T2-71
Dimensions	V5-T2-93



Contactors and Starters

Product Description

The Eaton NEMA® Space-Savings line of contactors and starters includes non-reversing and reversing contactors, electronic overload relays and a variety of related accessories. Because the Space-Savings family meets IEC, UL®, CSA® and CE standards, it is the perfect product solution for applications all over the world. The compact and easy to install Space-Savings line of NEMA contactors and starters is the efficient and effective solution for customer applications from Size 0 through Size 5.

Application Description

The Space-Savings line of NEMA power control was engineered to provide highly effective control and protection for a variety of loads, including motors, compressors, pumps, resistive, capacitor banks, isolation and others.

The Space-Savings contactors are perfectly suited for use in Motor Control Center applications where bucket space sizing is critical. With both AC and DC control and flexible communication options, the Space-Savings family can be easily integrated into various customer applications.

Features and Benefits

- AC control from 120V to 600V 50/60 Hz
- 24 Vdc control
- Reversing or non-reversing contactors and starters
- XTOE self-powered electronic overload relay
- Non-reversing starters to NEMA Size 5
- Panel or DIN rail mounting to NEMA Size 2
- IP20 finger and back-of-hand proof
- Large ambient temperature range, -25 to 50°C [-13 to 122°F]
- AC and DC controlled contactors in the same compact frame
- Low power consumption AC and DC coils
- Built-in NO or NC auxiliary contacts to 32A
- Plug-in accessories for reduced installation time
- Coil replacement on NEMA Size 0-5
- Contact replacement on NEMA Size 1-5
- Integrated suppressor NEMA Size 0-4 DC operated contactors and NEMA Size 5 AC and DC operated contactors

Standards and Certifications

- IEC EN 60947
- CE approved
- UL
- CSA
- ATEX
- RoHS



Catalog Number Selection

2

Space-Savings NEMA Starters with XTOE Electronic Overload Relays

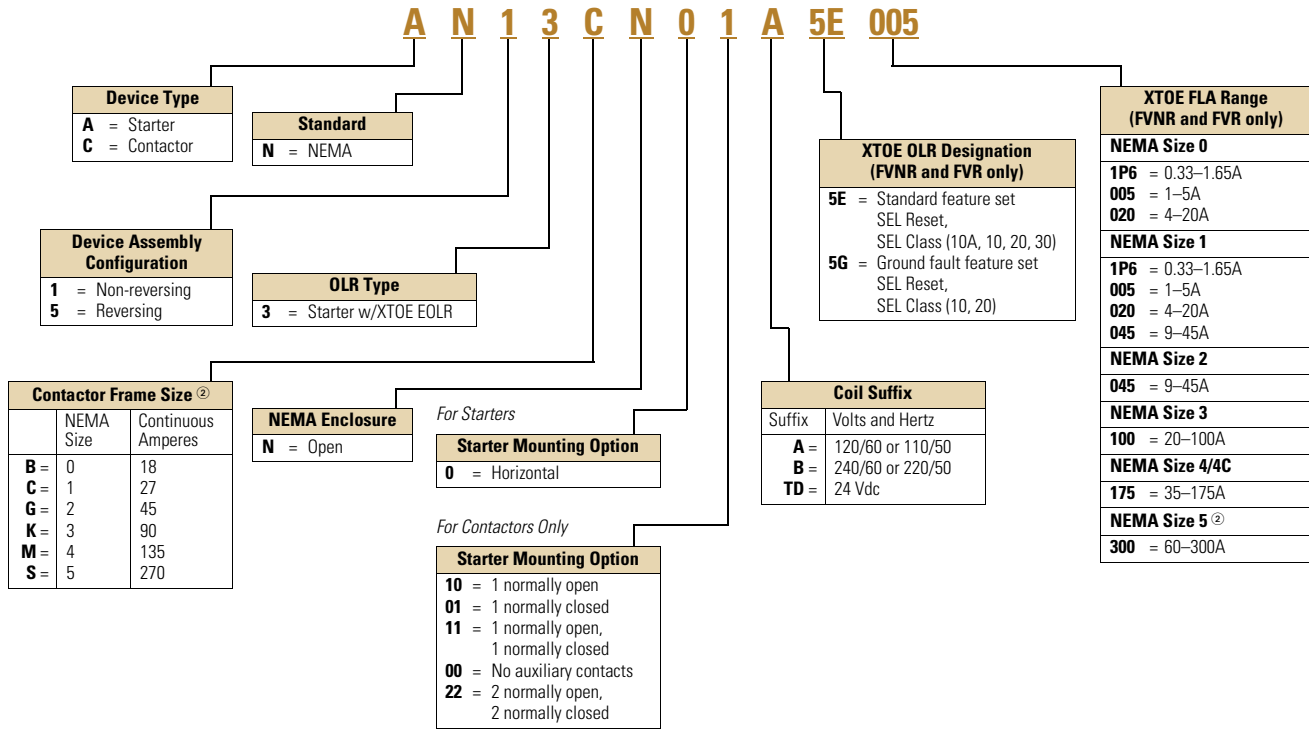

Product Selection

Type CN13/53 Space-Savings NEMA Contactors

NEMA Contactor Non-Reversing and Reversing



NEMA Size	Continuous Ampere Rating	Service Limit Current Rating (Amps)	Maximum UL Horsepower				Three-Pole Non-Reversing ⁽¹⁾ Catalog Number	Three-Pole Reversing ⁽¹⁾ Catalog Number		
			Single-Phase 115V	230V	Three-Phase 208V	240V				
0	18	21	1	2	3	3	5	5	CN13BN010_	—
1	27	32	2	3	7-1/2	7-1/2	10	10	CN13CN010_	CN53CN011_
2	45	52	3	7-1/2	10	15	25	25	CN13GN000_	CN53GN011_
3	90	104	7.5	15	25	30	50	50	CN13KN000_	CN53KN011_
4	135	156	—	—	40	50	100	100	CN13MN000_	—
5	270	311	—	—	75	100	200	200	CN13SN022_	—

Notes

- ⁽¹⁾ Underscore () indicates coils suffix required, see Coil Suffix table above.
- ⁽²⁾ NEMA Size 5 starter components to be ordered separately: Contactor (CN13SN022_), 60–300A CT kit, and 1–5A overload relay. See page **V5-T2-82** for CT kit and overload part numbers.

Type AN13/53 Space-Savings Starters with XTOE Electronic Overload Relays

NEMA Starter



Non-Reversing and Reversing

NEMA Size	Continuous Ampere Rating	Service Limit Current Rating (Amps)	Maximum UL Horsepower						Three-Pole Non-Reversing ^{①②} Catalog Number ^③	Three-Pole Reversing ^{①②} Catalog Number ^③
			Single-Phase		Three-Phase		480V	600V		
			115V	230V	208V	240V				
0	18	21	1	2	3	3	5	5	AN13BN0_5E_	AN53BN0_5E_
1	27	32	2	3	7-1/2	7-1/2	10	10	AN13CN0_5E_	AN53CN0_5E_
2	45	52	3	7-1/2	10	15	25	25	AN13GN0_5E_	AN53GN0_5E_
3	90	104	—	—	25	30	50	50	AN13KN0_5E_	AN53KN0_5E_
4	135	156	—	—	40	50	100	100	AN13MN0_5E_	AN53MN0_5E_
5 ^④	270	311	—	—	75	100	200	200	^④	—

Type AN13/53 Space-Savings Starters with XTOE Ground Fault Electronic Overload Relays

NEMA Starter with Ground Fault



Non-Reversing and Reversing

NEMA Size	Continuous Ampere Rating	Service Limit Current Rating (Amps)	Maximum UL Horsepower						Three-Pole Non-Reversing ^{①②} Catalog Number ^③	Three-Pole Reversing ^{①②} Catalog Number ^③
			Single-Phase		Three-Phase		480V	600V		
			115V	230V	208V	240V				
0	18	21	1	2	3	3	5	5	AN13BN0_5G_	AN53BN0_5G_
1	27	32	2	3	7-1/2	7-1/2	10	10	AN13CN0_5G_	AN53CN0_5G_
2	45	52	3	7-1/2	10	15	25	25	AN13GN0_5G_	AN53GN0_5G_
3	90	104	—	—	25	30	50	50	AN13KN0_5G_	AN53KN0_5G_
4	135	156	—	—	40	50	100	100	AN13MN0_5G_	AN53MN0_5G_
5 ^④	270	311	—	—	75	100	200	200	^④	—

XTOE Overload FLA Range (FVNR and FVR Starters Only) Magnet Coil Suffix

NEMA Size	OLR Code	FLA Range	OLR Code	FLA Rating	Coil Voltage	Suffix Code
0	1P6	0.33–1.65A	020	4.0–20A	Sizes 0–2 110V 50 Hz, 120V 60 Hz	A
	005	1.0–5.0A	—	—		
1	1P6	0.33–1.65A	020	4.0–20A	220V 50 Hz, 240V 60 Hz	B
	005	1.0–5.0A	045	9.0–45A		
2	—	—	045	9.0–45A	24–27 Vdc	TD
	—	—	—	—		
3	100	20–100A	—	—	Sizes 3, 4 100–120V 50/60 Hz	A
4	175	35–175A	—	—	190–240V 50/60 Hz	B
5 ^④	300	60–300A	—	—	24–27 Vdc	TD
					Sizes 5 100–120V 50/60 Hz	A
					24–48 Vdc	TD

Notes

- ① Underscore (_) indicates coils suffix required, see Coil Suffix table above.
- ② Underscore (_) indicates OLR designation required, see XTOE FLA Range table above.
- ③ For MCC replacement needs, contact MCC Aftermarket.
- ④ NEMA Size 5 starter components to be ordered separately: Contactor (CN13SN022_), 60–300A CT kit, and 1–5A overload relay. See page **V5-T2-82** for CT kit and overload part numbers.











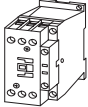

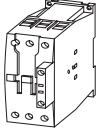

Accessories

2

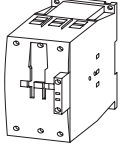
Auxiliary Contacts—Overview

Front-mounted snap-on auxiliary contacts for Space-Savings contactors are available with screw terminals in a variety of contact configurations.

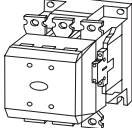
Auxiliary Contacts Possible Combinations

Frame Size	Catalog Number	Contactor	Built-In Auxiliary	Front (Top) Mount		Side-Mount		Total Auxiliary Contacts Available
				Two-Pole	Four-Pole	Single-Pole	Two-Pole	
0, 1	CN13BN0_ – CN13CN0_		1NO or 1NC	1	—	—	—	3
				—	1	—	—	5
				—	—	—	1	3
						—		—
2	CN13GN0_		—	1	—	—	2	6
				—	1	—	1	6
				—	—	—	—	—
						—		—
3, 4	CN13KN0_ – CN13MN0_		—	1	—	—	2	6
				—	1	—	2	8
				—	—	—	4	8
						—		—
5	CN13SN0		2NO–2NC	—	—	—	2	8
				—	—	—	—	—
				—	—	—	—	—
				—	—	—		—

Auxiliary Contacts

XTCEXF_

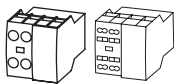

NEMA Size 0, 1 – Front (Top) Mount – Two-Pole

Conventional Thermal Current,
Open at 60°C
 $I_{th} = I_e$, AC-1 in Amps

	Contact Configuration	Circuit Symbol	Pkg. Qty. ①	Screw Terminal Catalog Number
16	2NO		5	XTCEXFAC20
16	1NO-1NC		5	XTCEXFAC11 ②
16	2NC		5	XTCEXFAC02

XTCEXF_



NEMA Size 0, 1 – Front (Top) Mount – Four-Pole

Conventional Thermal Current,
Open at 60°C
 $I_{th} = I_e$, AC-1 in Amps

	Contact Configuration	Circuit Symbol	Pkg. Qty. ①	Screw Terminal Catalog Number
16	4NO		5	XTCEXFAC40 ②
16	3NO-1NC		5	XTCEXFAC31 ②
16	2NO-2NC		5	XTCEXFAC22 ②
16	1NO-3NC		5	XTCEXFAC13
16	4NC		5	XTCEXFAC04

XTCEXSCC11

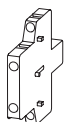

NEMA Size 0, 1 – Side-Mount – Two-Pole

Conventional Thermal Current,
Open at 60°C
 $I_{th} = I_e$, AC-1 in Amps

	Contact Configuration	Circuit Symbol	Pkg. Qty. ①	Screw Terminal Catalog Number
10	1NO-1NC		1	XTCEXSCC11 ③

Notes

No auxiliary contacts can be fitted between two contactors.

- ① Orders must be placed in multiples of package quantity listed.
- ② To avoid duplicate terminal numbers in contact sequence, these auxiliary contacts should only be used with contactors having a built-in 1NO contact (XTCE...B10_, XTCE...C10_).
- ③ Can be mounted to the left side of contactor only. Cannot be used in combination with front (top) mount auxiliary contacts or mechanical interlocks.

2.2

NEMA Contactors and Starters

Space-Savings Series

2

XTCEXF_



NEMA Sizes 2-4 – Two-Pole

Conventional Thermal Current, Open at 60°C $I_{th} = I_e$, AC-1 in Amps	Contact Configuration	Circuit Symbol	Pkg. Qty. ①	Screw Terminal Catalog Number
16	2NO		5	XTCEXFBG20
16	1NO-1NC		5	XTCEXFBG11
16	2NC		5	XTCEXFBG02

XTCEXF_

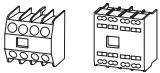

NEMA Sizes 2-4 – Four-Pole

Conventional Thermal Current, Open at 60°C $I_{th} = I_e$, AC-1 in Amps	Contact Configuration	Circuit Symbol	Pkg. Qty. ①	Screw Terminal Catalog Number
16	4NO-0NC		5	XTCEXFBG40
16	3NO-1NC		5	XTCEXFBG31
16	2NO-2NC		5	XTCEXFBG22
16	2NO-2NC		5	XTCEXFBG22
16	1NO-3NC		5	XTCEXFBG13

XTCEXS_

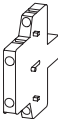

NEMA Sizes 2-4, Side Mount (Snap-On) – Two-Pole

Conventional Free Air Thermal Current, $I_{th} = I_e$, AC-1 in Amps	Contact Configuration	Circuit Symbol	Pkg. Qty. ①	Screw Terminal Catalog Number
10	1NO-1NC		1	XTCEXSBN11

XTCEXS_

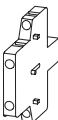

NEMA Size 5, Side Mount (Screw Mount) – Two-Pole

Conventional Free Air Thermal Current, $I_{th} = I_e$, AC-1 in Amps	Contact Configuration	Circuit Symbol	Pkg. Qty. ①	Screw Terminal Catalog Number
10	1NO-1NC		1	XTCEXSBR11 ②

Notes

No auxiliary contacts can be fitted between two contactors.

① Orders must be placed in multiples of package quantity listed.

② For replacement only. XTCEXSBR11 and XTCEXSBLR11 cannot be added onto side mount auxiliaries that come with the Size 5 contactors as standard. To add auxiliaries onto the included side auxiliaries on Size 5 contactors, use XTCEXSCR11.

Suppressors

The switching of contactor coils can generate voltage transients that may cause arcing on switch contacts and/or damage electronics on the control line. Either an RC or varistor suppressor is recommended in these types of applications. All Space-Savings DC contactor coils have built-in suppression.

Varistor suppressors clamp the voltage transient above the maximum coil voltage and are recommended when the level of the transient is known to not exceed the coil voltage. RC suppressors slow and reduce the level of the voltage transient but do not clamp them at a specific level. The slowing of the transient can reduce electrical interference. These are recommended in applications where operating rates are high.

XTCEXVS_



Varistor Suppressor ^{①②}

Voltage	For Use with...	Pkg. Qty. ^③	Catalog Number
48–130	CN13BNO_ CN13CNO_	10	XTCEXVSCA
48–130	CN13GNO_	10	XTCEXVSFA

Contact Sequence



XTCEXRS_



RC Suppressor ^{①②}

Voltage	For Use with...	Pkg. Qty. ^③	Catalog Number
24–48	CN13GNO_	—	XTCEXRSFW
110–130	—	—	XTCEXRSFA

Contact Sequence



Notes

- ① Note dropout delay.
- ② For AC operated contactors, 50–60 Hz. Sizes 0–5 DC operated contactors and Size 5 AC operated contactors have a built-in suppressor circuit.
- ③ Orders must be placed in multiples of package quantity listed.
- ④ In addition to the built-in suppressor circuit for DC actuated contactors. Prevents negative breaking voltage when contactors are used in combination with a safety PLC.
- ⑤ For two contactors with AC or DC operated magnet system which are horizontally or vertically mounted. For Sizes 0–4, mechanical lifespan is 2.5×10^6 operations and the distance between contactors is 0 mm. For Size 5, mechanical lifespan is 5×10^6 operations and no auxiliary contact can be mounted between the mechanical interlock and the contactor—the distance between contactors is 15 mm.
- ⑥ XTCEXMLG and XTCEXMLN consist of an interlock element and mounting plate.

Additional Accessories

Mechanical Interlock ^⑤

XTCEXML_



For Use with...	Pkg. Qty. ^③	Catalog Number
CN13BNO_ CN13CNO_	1	XTCEXMLC
CN13GNO_	1	XTCEXMLD
CN13KNO_ CN13MNO_	1	XTCEXMLG ^⑥
CN13SNO_	1	XTCEXMLM

XTCEXMLM



XTCEXRL_



Reversing Link Kits

For Use with...	Pkg. Qty. ^③	Catalog Number
CN13BNO_ CN13CNO_	1	XTCEXRLC
CN13GNO_	1	XTCEXRLD
CN13KNO_ CN13MNO_	1	XTCEXRLG

Main current wiring for reversing combinations. Includes paralleling bridge and reversing bridge. Does not include mechanical interlock, see table on this page.

XTCEXTLA400



Terminal Lug Assembly

For Use with...	Pkg. Qty. ^③	Catalog Number
CN13SNO_	1	XTCEXTLA400

For connection of: round conductor, flexible and stranded, flat strip conductor, with control circuit terminal. See **Page V5-T2-72** for terminal capacities.

XTCEXTS_



Terminal Shroud

For Use with...	Pkg. Qty. ^③	Catalog Number
CN13SNO_	1	XTCEXTS400

Protection against direct contact with connection lugs when touched vertically from the front.

Renewal Parts

2

XTCERENC_



Replacement Coils

Voltage	Coil Suffix	Catalog Number
Size 0, 1		
110/50 120/60	A	XTCERENCOILCA
220/50 240/60	B	XTCERENCOILCB
24–27 Vdc	TD	XTCERENCOILCTD
Size 2		
110/50 120/60	A	XTCERENCOILDA
220/50 240/60	B	XTCERENCOILDB
24–27 Vdc	TD	XTCERENCOILDTD
Size 3, 4		
100–120V 50/60	A	XTCERENCOILGA
190–240V 50/60	B	XTCERENCOILGB
24–27 Vdc	TD	XTCERENCOILGTD
Size 5		
110–250 Vac/Vdc	A	XTCERENCOILLA
24–48 Vdc	TD	XTCERENCOILLTD

Replacement Contact Kit

For Use with...	Catalog Number
CN13GN0_	XTCERENCONTACTD
CN13SN0_	XTCERENCONTACTL

Replacement Arc Chamber

For Use with...	Catalog Number
CN13SN0_	XTCERENARC250

Parallel Link

Description	XTCEXPLKB	XTCEXPLKC	XTCEXPLKD	XTCEXPLKG	XTCEXPLK185
Terminal capacity					
Solid (mm ²)	1–16	16	16	—	—
Flexible with ferrule (mm ²)	1 x (0.5–25) 2 x (0.5–16)	1 x (16–35)	1 x (16–120)	—	—
Stranded (mm ²)	1 x (0.5–25) 2 x (0.5–16)	1 x (16–50)	1 x (16–120)	1 x (35–300) 2 x (35–120)	—
Flat conductor—number of segments x width x thickness (mm)	6 x 9 x 0.8	—	—	2 x (11 x 21 x 1)	1 x (6 x 16 x 0.8) 2 x (20 x 32 x 0.5) 2 x (11 x 21 x 1)
Tightening torque (Nm)	4	4	14	—	—
Tools					
Pozidriv screwdriver	Size 2	Size 2	—	—	—
Hexagon socket head spanner—SW (mm)	—	—	5	6	—
Conventional thermal current					
Three-pole (I _{th}) A	50	100	180	400	—
Four-pole (I _{th}) A	60	—	—	—	—

Cable Terminal Block, Flat Cable Terminal

Description	XTCEXTLA400	XTCEXPLK185	XTCEXTFB650	XTCEXTFB820
Terminal capacity				
Stranded (mm ²)	1 x (120–300) 2 x (70–240)	—	—	—
Stranded (AWG)	1 x (250–600 kcmil) 2 x (2/0–500 kcmil)	—	—	—
Flat conductor—number of segments x width x thickness (mm)	—	1 x (6 x 16 x 0.8) 2 x (20 x 32 x 0.5) 2 x (11 x 21 x 1)	1 x (6 x 16 x 0.8) 2 x (20 x 32 x 0.5) 2 x (11 x 21 x 1)	1 x (6 x 16 x 0.8) 2 x (10 x 40 x 1) 2 x (20 x 40 x 0.5)

AC Ratings—AC-1 Operation

Description	CN13B	CN13C	CN13G	CN13K	CN13M	CN13S
Conventional free air thermal current, three-pole, 50–60 Hz						
Open						
at 40°C (I _{th})	40A	45A	80A	130A	190A	490
at 50°C (I _{th})	38A	43A	71A	125A	180A	438
at 55°C (I _{th})	37A	42A	68A	115A	170A	418
at 60°C (I _{th})	35A	40A	65A	110A	160A	400
Enclosed	32A	36A	58A	100A	144A	315
Conventional free air thermal current, single-pole (I _{th})						
Open	88A	100A	162A	275A	400A	—
Enclosed	80A	90A	145A	250A	360A	—

Space-Savings Contactors—NEMA Sizes 0–2

Description	Size 0 CN13BN010_	Size 1 CN13CN010_	Size 2 CN13GN000_
General			
Standards	IEC/EN 60947, VDE 0660, UL, CSA, CCC, RoHS	IEC/EN 60947, VDE 0660, UL, CSA, CCC, RoHS	IEC/EN 60947, VDE 0660, UL, CSA, CCC, RoHS
Weights in kg [lb]			
AC operated	0.42 [0.93]	0.42 [0.93]	0.9 [2.0]
DC operated	0.48 [1.06]	0.48 [1.06]	1.1 [2.4]
Mechanical life—operations	10,000,000	10,000,000	10,000,000
Climatic proofing	①	①	①
Insulation voltage (U _i) Vac	690	690	690
Impulse withstand voltage (U _{imp}) Vac	8000	8000	8000
Operating voltage (U _e) Vac	690	690	690
Safe isolation to VDE 0106 Part 101 and Part 101/A1			
Between coil and contacts (Vac)	440	440	440
Between contacts (Vac)	238	440	440
Making capacity (amps)	238	384	910
Breaking capacity (amps)			
220/230V	170	320	650
380/400V	170	320	650
500V	170	320	650
660/690V	120	180	370
Short-circuit protection rating maximum fuse (amps)			
Type 2 coordination ②			
400V; gG/gL 500V	25	63	125
690V; gG/gL 690V	25	35	80
Type 1 coordination ②			
400V; gG/gL 500V	63	125	250
690V; gG/gL 690V	50	63	100
Degree of protection	IP00	IP00	IP00
Protection against direct contact when actuated from front (IEC 536)	Finger and back-of-hand proof	Finger and back-of-hand proof	Finger and back-of-hand proof
Terminal capacity main cable—screw terminals			
Solid (mm ²)	1 x (0.75–16) 2 x (0.75–10)	1 x (0.75–16) 2 x (0.75–10)	1 x (0.75–16) 2 x (0.75–10)
Flexible with ferrule (mm ²)	1 x (0.75–16) 2 x (0.75–10)	1 x (0.75–16) 2 x (0.75–10)	1 x (2.5–35) 2 x (2.5–25)
Stranded (mm ²)	1 x 16	1 x 16	1 x (16–50) 2 x (16–35)
Solid or stranded (AWG)	18–6	18–6	12–2
Flat conductor (number of segments x width x thickness) (mm)	—	—	2 x (6 x 9 x 0.8)

Notes

① Damp heat, constant, to IEC 60068-2-78; damp heat, cyclic, to IEC 60 068-2-30.

② IEC 60947 Standard.

Space-Savings Contactors—NEMA Sizes 0–2, continued

2

Description	Size 0 CN13BN010_	Size 1 CN13CN010_	Size 2 CN13GN000_
General, continued			
Main cable connection screw/bolt	M5	M5	M6
Tightening torque			
Nm	3	3	3.3
Lb-in	26.6	26.6	29.2
Terminal capacity control circuit cable—screw terminals			
Solid (mm ²)	1 x (0.75–4) 2 x (0.75–4)	1 x (0.75–4) 2 x (0.75–4)	1 x (0.75–4) 2 x (0.75–4)
Flexible with ferrule (mm ²)	1 x (0.75–2.5) 2 x (0.75–2.5)	1 x (0.75–2.5) 2 x (0.75–2.5)	1 x (0.75–2.5) 2 x (0.75–2.5)
Solid or stranded (AWG)	18–14	18–14	18–14
Control circuit cable connection screw/bolt	M3.5	M3.5	M3.5
Tightening torque			
Nm	1.2	1.2	1.2
Lb-in	10.6	10.6	10.6
Tools			
Main and control circuit cable—screw terminals	Size 2	Size 2	Size 2
Pozidriv screwdriver	0.8 x 5.5	0.8 x 5.5	0.8 x 5.5
Standard screwdriver	1 x 6	1 x 6	1 x 6
Terminal capacity control circuit cable—spring cage terminals			
Solid (mm ²)	1 x (0.75–2.5) 2 x (0.75–2.5)	1 x (0.75–2.5) 2 x (0.75–2.5)	1 x (0.75–2.5) 2 x (0.75–2.5)
Flexible (mm ²)	1 x (0.75–2.5) 2 x (0.75–2.5)	1 x (0.75–2.5) 2 x (0.75–2.5)	1 x (0.75–2.5) 2 x (0.75–2.5)
Flexible with ferrule (mm ²)	1 x (0.75–2.5) 2 x (0.75–2.5)	1 x (0.75–2.5) 2 x (0.75–2.5)	1 x (0.75–2.5) 2 x (0.75–2.5)
Solid or stranded (AWG)	18–14	18–14	18–14
Tools			
Main and control circuit cable—spring cage terminals			
Stripping length (mm)	10	10	10
Screwdriver blade width (mm)	3.5	3.5	3.5
Mounting position, AC and DC operated			
Ambient temperature			
Open	–25 to 60°C [–13 to 140°F]	–25 to 60°C [–13 to 140°F]	–25 to 60°C [–13 to 140°F]
Enclosed	–25 to 40°C [–13 to 104°F]	–25 to 40°C [–13 to 104°F]	–25 to 40°C [–13 to 104°F]
Ambient storage temperature	–40 to 80°C [–40 to 176°F]	–40 to 80°C [–40 to 176°F]	–40 to 80°C [–40 to 176°F]
Environmental			
Mechanical shock resistance (IEC/EN 60068-2-27)			
Main contact—NO Contact	10	10	1
Auxiliary contact—NO Contact	7	7	7
Auxiliary contact—NC Contact	5	5	5
Overvoltage category/pollution degree	III/3	III/3	III/3

Space-Savings Contactors—NEMA Sizes 3, 4

Description	Size 3 CN13KN000_	Size 4 CN13MN000_
General		
Standards	IEC/EN 60947, VDE 0660, UL, CSA, CCC, RoHS	IEC/EN 60947, VDE 0660, UL, CSA, CCC, RoHS
Weights in kg [lb]		
AC operated	2 [4.41]	2 [4.41]
DC operated	2.1 [4.63]	2.1 [4.63]
Mechanical life—operations	10,000,000	10,000,000
Climatic proofing	①	①
Insulation voltage (U _i) Vac	690	690
Impulse withstand voltage (U _{imp}) Vac	8000	8000
Operational voltage (U _a) Vac	690	690
Safe isolation to VDE 0106 Part 101 and Part 101/A1		
Between coil and contacts (Vac)	690	690
Between contacts (Vac)	690	690
Making capacity (amps)	1610	2100
Breaking capacity (amps)		
220/230V	1150	1500
380/400V	1150	1500
500V	1150	1500
660/690V	1100	1200
1000V	—	—
Short-circuit protection rating maximum fuse		
Type 2 coordination ②		
400V; gG/gL 500V	250	25
690V; gG/gL 690V	25	250
Type 1 coordination ②		
400V; gG/gL 500V	250	250
690V; gG/gL 690V	250	250
Degree of protection	IP00	IP00
Protection against direct contact when actuated from front (IEC 536)	Finger and back-of-hand proof	Finger and back-of-hand proof
Terminal capacity main cable—screw terminals		
Solid (mm ²)	—	—
Flexible with ferrule (mm ²)	1 x (10–95) 2 x (10–70)	1 x (10–95) 2 x (10–70)
Stranded (mm ²)	1 x (10–95) 2 x (10–20)	1 x (10–95) 2 x (10–20)
Flat conductor (number of segments x width x thickness) (mm)	2 x (6 x 16 x 0.8)	2 x (6 x 16 x 0.8)
Solid or stranded (AWG)	8–3/0	8–3/0
Main cable connection screw/bolt	M10	M10
Tightening torque		
Nm	14	14
Lb-in	123.9	123.9

Notes

① Damp heat, constant, to IEC 60068-2-78; damp heat, cyclic, to IEC 60 068-2-30.

② IEC 60947 Standard.

Space-Savings Contactors—NEMA Sizes 3, 4, continued

2

Description	Size 3 CN13KN000_	Size 4 CN13MN000_
General, continued		
Terminal capacity control circuit cable—screw terminals		
Solid (mm ²)	1 x (0.75–4) 1 x (0.75–4)	1 x (0.75–4) 1 x (0.75–4)
Flexible with ferrule (mm ²)	1 x (0.75–2.5) 2 x (0.75–2.5)	1 x (0.75–2.5) 2 x (0.75–2.5)
Solid or stranded (AWG)	18–14	18–14
Control circuit cable connection screw/bolt	M3.5	M3.5
Tightening torque		
Nm	1.2	1.2
Lb-in	10.6	10.6
Tools		
Main circuit cable—screw terminals		
Hexagon socket-head spanner (mm)	5	5
Control circuit cable—screw terminals		
Pozidriv screwdriver	0.8 x 5.5	0.8 x 5.5
Standard screwdriver	1 x 6	1 x 6
Terminal capacity control circuit cable—spring cage terminals		
Solid (mm ²)	1 x (0.75–2.5) 2 x (0.75–2.5)	1 x (0.75–2.5) 2 x (0.75–2.5)
Flexible (mm ²)	1 x (0.75–2.5) 2 x (0.75–2.5)	1 x (0.75–2.5) 2 x (0.75–2.5)
Flexible with ferrule (mm ²)	1 x (0.75–2.5) 2 x (0.75–2.5)	1 x (0.75–2.5) 2 x (0.75–2.5)
Solid or stranded (AWG)	18–14	18–14
Tools		
Control circuit cable—spring cage terminals		
Stripping length (mm)	10	10
Screwdriver blade width (mm)	3.5	3.5
Mounting position, AC and DC operated		
Ambient temperature		
Open	–25 to 60°C [–13 to 140°F]	–25 to 60°C [–13 to 140°F]
Enclosed	–25 to 40°C [–13 to 104°F]	–25 to 40°C [–13 to 104°F]
Ambient storage temperature	–40 to 80°C [–40 to 176°F]	–40 to 80°C [–40 to 176°F]
Environmental		
Mechanical shock resistance (IEC/EN 60068-2-27)		
Half-sinusoidal shock 10 ms		
Main contact—NO contact	10g	10g
Auxiliary contact—NO contact	7g	7g
Auxiliary contact—NC contact	5g	5g
Overvoltage category/pollution degree	III/3	III/3

Space-Savings Contactors—NEMA Size 5

Description	Size 5 CN13SN022_
General	
Standards	IEC/EN 60947, VDE 0660, UL, CSA
Weights in kg [lb]	6.5 [14.3]
Mechanical life—operations	10,000,000
Mechanical operating frequency (ops/hr)	
AC operated	3000
DC operated	3000
Climatic proofing	①
Insulation voltage (U _i) Vac	1000
Impulse withstand voltage (U _{imp}) Vac	8000
Operating voltage (U _o) Vac	1000
Safe isolation to VDE 0106 Part 101 and Part 101/A1	
Between coil and contacts (Vac)	500
Between contacts (Vac)	500
Making capacity (amps)	3000
Breaking capacity (amps)	
220/230V	2500
380/400V	2500
500V	2500
660/690V	2500
1000V	760
Short-circuit protection rating maximum fuse	
Type 2 coordination ②	
400V; gG/gL 500V	315
690V; gG/gL 690V	315
1000V; gG/gL 1000V	160
Type 1 coordination ②	
400V; gG/gL 500V	400
690V; gG/gL 690V	400
1000V; gG/gL 1000V	200
Degree of protection	IP00
Protection against direct contact when actuated from front (IEC 536)	Finger and back-of-hand proof with terminal shroud or terminal block
Main cable cross-section	
Flexible with cable lug (mm ²)	50–240
Stranded with cable lug (mm ²)	70–240
Solid or stranded (AWG)	1/0–250 kcmil
Flat conductor (mm)	③
Bus bar—width in mm	25
Main cable connection screw/bolt	M10
Tightening torque	
Nm	24
Lb-in	213

Notes

- ① Damp heat, constant, to IEC 60068-2-78; damp heat, cyclic, to IEC 60 068-2-30.
- ② IEC 60947 Standard.
- ③ Screw tightening with flat cable terminal or cable terminal blocks. See terminal capacity for cable terminal blocks.
- ④ When using contactors for group compensation, a minimum inductance of approx. 6 uH per capacitor must be available to limit the high inrush current peaks. This corresponds to an air-cored coil with five windings and a coil diameter of approximately 140 mm. The conductor cross-section must be selected according to the rated current per phase.

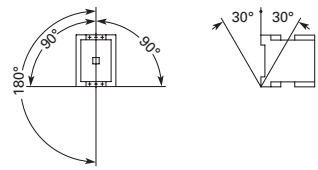
Description	Size 5 CN13SN022_
General, continued	
Control circuit cable cross-sections	
Solid (mm ²)	1 x (0.75–2.5) 2 x (0.75–2.5)
Flexible with ferrule (mm ²)	1 x (0.75–2.5) 2 x (0.75–2.5)
Solid or stranded (AWG)	2 x (18–12)
Control circuit cable connection screw/bolt	M3.5
Tightening torque	
Nm	1.2
Lb-in	10.6
Tools	
Main cable wrench	16 mm
Control circuit cable pozidriv screwdriver	Size 2
Mounting position, AC and DC operated	
Ambient temperature	–25 to 60°C [–13 to 140°F]
Ambient storage temperature	–40 to 80°C [–40 to 176°F]
Environmental	
Mechanical shock Resistance (IEC/EN 60068-2-27)	
Half-sinusoidal shock 10 ms	
Main contact—NO contact	10g
Auxiliary contact—NO contact	10g
Auxiliary contact—NC contact	8g
Overvoltage category/pollution degree	III/3
Switching capacity, kVAR ④	
Individual compensation	
230V	—
400/420/440V	—
525V	—
690V	—
Group compensation, with choke	
230V	100
400/420/440V	190
525V	260
690V	340
Group compensation, without choke	
230V	—
400/420/440V	—
525V	—
690V	—

XTOE/XT Electronic Overload Relay



XTOE/XT Electronic Overload Relay

Product Description

Eaton's new electronic overload relay (EOL) is the most compact, high-featured, economical product in its class. Designed on a global platform, the new EOL covers the entire power control spectrum including NEMA, IEC and DP Contactors. The standard NEMA and DP versions are offered with the C440 designation while the Space-Savings NEMA and IEC versions have the XTOE designation. The electronic design provides reliable, accurate and value driven protection and communications capabilities in a single compact device. It is the flexible choice for any application requiring easy-to-use, reliable protection.

Eaton has a long history of innovations and product development in motor control and protection, including both traditional NEMA, as well as IEC control. It was from this experience that the XTOE was developed, delivering new solutions to meet today's demands.

XTOE is a self-powered electronic overload relay available up to 175A as a self contained unit. With external CTs, XTOE can protect motor up to 1500 FLA. Available add-on accessories include remote reset capability and communication modules with I/O for DeviceNet, PROFIBUS, Modbus, EtherNet/IP, and Modbus TCP.

Contents

Description

	<i>Page</i>
XTOE/XT Electronic Overload Relay	
Standards and Certifications	V5-T2-79
Catalog Number Selection	V5-T2-80
Product Selection	V5-T2-81
Accessories	V5-T2-83
Technical Data and Specifications	V5-T2-85
Dimensions	V5-T2-93



Features and Benefits

Features

- Reliable, accurate, electronic motor protection
- Easy to select, install and maintain
- Compact size
- Flexible, intelligent design
- Global product offering—available with NEMA, IEC and DP power control

Size/Range

- Broad FLA range (0.33–1500A)
- Selectable trip class (10A, 10, 20, 30)
- Direct mounting to NEMA, IEC and DP contactors
- Most compact electronic overload in its class

Motor Control

- Two B600 alarm (NO) and fault (NC) contacts
- Test/Trip button

Motor Protection

- Thermal overload
- Phase loss
- Selectable (ON/OFF) phase unbalance
- Selectable (ON/OFF) ground fault

User Interface

- Large FLA selection dial
- Trip status indicator
- Operating mode LED
- DIP switch selectable trip class, phase unbalance and ground fault
- Selectable Auto/Manual reset

Feature Options

- Remote reset
 - 120 Vac
 - 24 Vac
 - 24 Vdc
- Tamper-proof cover
- Communications modules
 - Modbus RTU RS-485
 - DeviceNet with I/O
 - PROFIBUS with I/O
 - Modbus RTU with I/O
 - Ethernet IP with I/O
 - Modbus TCP with I/O

Benefits

Reliability and Improved Uptime

- XTOE provides the users with peace of mind knowing that their assets are protected with the highest level of motor protection and communication capability in its class
- Extends the life of plant assets with selectable motor protection features such as trip class, phase unbalance and ground fault
- Protects against unnecessary downtime by discovering changes in your system (line/load) with remote monitoring capabilities
- Status LED provides added assurance that valuable assets are protected by indicating the overload operational status

Flexibility

- Available with NEMA, IEC and DP contactors
- Improves return on investment by reducing inventory carrying costs with wide FLA adjustment (5:1) and selectable trip class
- Design incorporates built-in ground fault protection thus eliminating the need for separate CTs and modules
- Flexible communication with optional I/O enables easy integration into plant management systems for remote monitoring and control
- Available as an open component and in enclosed control and motor control center assemblies

Monitoring Capabilities

- Individual phase currents RMS
- Average three-phase current RMS
- Thermal memory
- Fault indication (overload, phase loss, phase unbalance, ground fault)

Safety

- IP 20 rated terminal blocks
- Available in Eaton's industry leading FlashGard MCCs
- Tested to the highest industry standards such as UL, CSA, CE and IEC
- RoHS compliant

Standards and Certifications

- UL
- CSA
- CE
- NEMA
- IEC/EN 60947 VDE 0660
- ISO 13849-1 (EN954-1)
- RoHS
- ATEX directive 94/9/EC
- Equipment Group 2, Category 2



Electronic Overload Education

Description	Definition	Cause	Effect if not Protected	XTOE/XT Protection
Motor Protection				
Thermal overload	Overload is a condition in which current draw exceeds 115% of the full load amperage rating for an inductive motor.	<ul style="list-style-type: none"> • An increase in the load or torque that is being driven by the motor. • A low voltage supply to the motor causes the current to go high to maintain the power needed. • A poor power factor causing above normal current draw. 	<ul style="list-style-type: none"> • Increase in current draw leads to heat and insulation breakdown, which can cause system failure. • Increase in current can increase power consumption and waste valuable energy. 	<ul style="list-style-type: none"> • Thermal trip behavior is defined by UL, CSA and IEC standards. • Trip class is settable from 10A, 10, 20, 30
Ground fault	A line to ground fault.	A current leakage path to ground.	An undetected ground fault can burn through multiple insulation windings, ultimately leading to motor failure, not to mention risk to equipment or personnel	Fixed protective setting that takes the starter offline if ground fault current exceeds 50% of the FLA dial setting, i.e., if the FLA dial is set to 12A, the overload relay will trip if the ground current exceeds 6A.
Unbalanced phases (voltage and current)	Uneven voltage or current between phases in a three-phase system.	When a three-phase load is powered with a poor quality line, the voltage per phase may be unbalanced.	Unbalanced voltage causes large unbalanced currents and as a result this can lead to motor stator windings being overloaded, causing excessive heating, reduced motor efficiency and reduced insulation life.	Fixed protective setting that takes the starter offline if a phase drops below 50% of the other two phases.
Phase loss—current (single-phasing)	One of the three-phase voltages is not present.	Multiple causes, loose wire, improper wiring, grounded phase, open fuse, etc.	Single-phasing can lead to unwanted motor vibrations in addition to the results of unbalanced phases as listed above.	Fixed protective setting that takes the starter offline if a phase is lost.

2.2

NEMA Contactors and Starters

Space-Savings Series

Catalog Number Selection

2

XT Electronic Overload Relay—NEMA Space-Savings

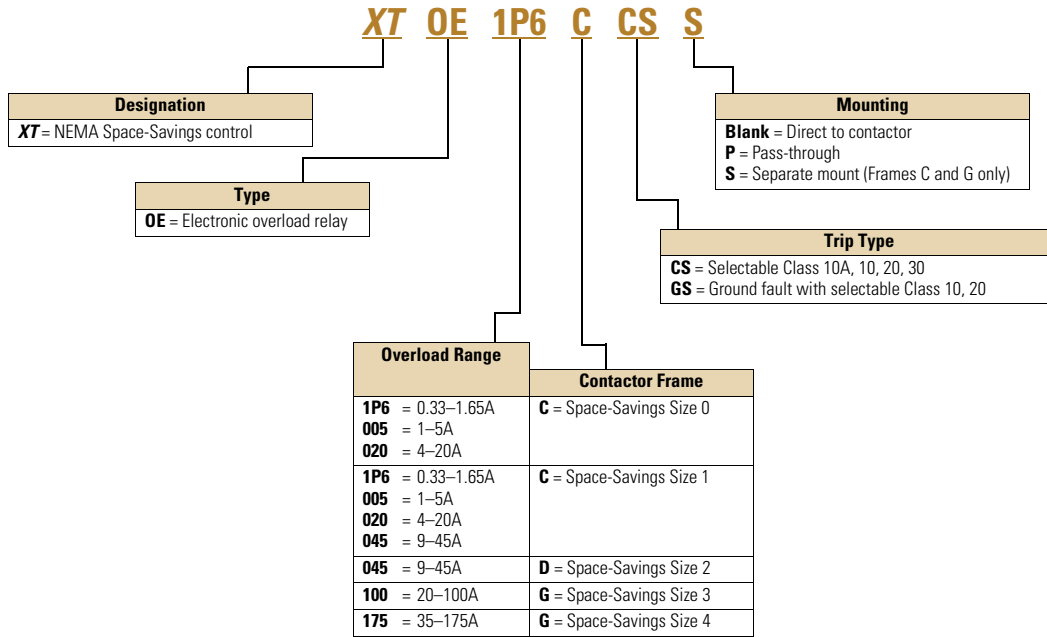

Product Selection

XT Electronic Overload Relays

XTOE for Direct Mount to NEMA Size 1



XT Electronic Overload Relays for Direct Mount to NEMA Space-Savings Contactors

NEMA Space-Savings Size	For Use with Contactor	Overload Range (Amps)	Contact Sequence	Frame Size	Auxiliary Contact Configuration	Catalog Number
0	CN13BN010_	0.35–1.65		45 mm	NO-NC	XTOE1P6CCS
		1–5				XTOE005CCS
		4–20				XTOE020CCS
1	CN13CN010_	0.35–1.65		45 mm	NO-NC	XTOE1P6CCS
		1–5				XTOE005CCS
		4–20				XTOE020CCS
		9–45				XTOE045CCS
2	CN13GN000_	9–45		45 mm	NO-NC	XTOE045DCS
		20–100		55 mm	NO-NC	XTOE100DCS
3	CN13KN000_	20–100		55 mm	NO-NC	XTOE100GCS
4	CN13MN000_	35–175		110 mm	NO-NC	XTOE175GCS

XTOE for Direct Mount to NEMA Size 4



XT Electronic Overload Relays with Ground Fault for Direct Mount to NEMA Space-Savings Contactors

NEMA Space-Savings Size	For Use with Contactor	Overload Range (Amps)	Contact Sequence	Frame Size	Auxiliary Contact Configuration	Catalog Number
0	CN13BN010_	0.33–1.65		45 mm	NO-NC	XTOE1P6CGS
		1–5				XTOE005CGS
		4–20				XTOE020CGS
1	CN13CN010_	0.33–1.65		45 mm	NO-NC	XTOE1P6CGS
		1–5				XTOE005CGS
		4–20				XTOE020CGS
		9–45				XTOE045CGS
2	CN13GN000_	9–45		45 mm	NO-NC	XTOE045DGS
		20–100		55 mm	NO-NC	XTOE100DGS
3	CN13KN000_	20–100		55 mm	NO-NC	XTOE100GGS
4	CN13MN000_	35–175		110 mm	NO-NC	XTOE175GGS

2.2

NEMA Contactors and Starters

Space-Savings Series

2

1-5A OL with CTs



XT Electronic Overload Relays for use with Size 5 NEMA Space-Savings Contactors

Use CTs and 1-5A **XT** overload relay. CT kit does not include overload relay (order separately).

Space-Savings Contactor Size	For Use with Contactor	CT Range (Amps)	Description	CT Kit Catalog Number	Terminal Size	Overload Relay Catalog Number
1	CN13SN022_	60-300	300: 5 panel-mount CT kit with integrated lugs	ZEB-XCT300	750 kcmil (2) 250 kcmil 3/0 Cu/Al	XTOE005CCSS

45 mm XT for Separate Mount



XT Electronic Overload Relays for Separate Mount

ZEB kits are not recommended for use with XTOE overload relays with ground fault option.

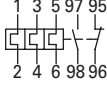
Overload Range (Amps)	Frame Size	Contact Sequence	Type	Overload Relay Catalog Number	Overload Relay with Ground Fault Catalog Number
Overload Relay					
0.33-1.65	45 mm	1 3 5 97 95	ZEB32-1,65/KK	XTOE1P6CCSS	XTOE1P6CGSS
1-5			ZEB32-5/KK	XTOE005CCSS	XTOE005CGSS
4-20			ZEB32-20/KK	XTOE020CCSS	XTOE020CGSS
9-45			ZEB32-45/KK	XTOE045CCSS	XTOE045CGSS
20-100	55 mm		ZEB150-100/KK	XTOE100GCSS	XTOE100GGSS
35-175	110 mm		ZEB150-175/KK	XTOE175GCSS	XTOE175GGSS

XT Electronic Overload Relay for Pass-Through Design

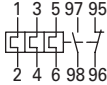

Pass-through design does not include any lugs to land wires. Terminate motor leads directly on contactor.

Overload Range (Amps)	Frame Size	Contact Sequence	Type	Overload Relay Catalog Number	Overload Relay with Ground Fault Catalog Number
35-175	110 mm	1 3 5 97 95	ZEB150-175/PT	XTOE175GCSP	XTOE175GGSP
					

Accessories

CT Kits

Accessories

	Description	Catalog Number
 <p>Safety Cover</p>	<p>Safety Cover</p> <p>Clear Lexan cover that mounts on top of the FLA dial and DIP switches when closed.</p>	<p>ZEB-XSC</p>
 <p>Reset Bar</p>	<p>Reset Bar</p> <p>Assembles to the top of the overload to provide a larger target area for door mounted reset operators.</p>	<p>ZEB-XRB</p>
 <p>Remote Reset</p>	<p>Remote Reset</p> <p>Remote reset module (24 Vdc) ①</p> <p>Remote reset module (120 Vac) ①</p> <p>Remote reset module (24 Vac) ①</p>	<p>C440-XCOM</p> <p>ZEB-XRR-120</p> <p>ZEB-XRR-24</p>

Communication

The C440/XTOE is provided with two levels of communication capability.

Basic Communication via Expansion Module—Monitoring Only

Basic communication on the C440 is accomplished using an expansion module (C440-XCOM). The expansion module plugs into the expansion bay on the C440 overload relay, enabling communications with the overload via their Modbus RTU (RS-485) network. No additional cards or modules are required. See figure below.



Basic Communication—Modbus

Advanced Communication—Monitoring and Control

C440 also has the ability to communicate on industrial protocols such as Modbus RTU, DeviceNet, PROFIBUS, Modbus TCP, and EtherNet/IP while providing control capability using I/O.

An expansion module (C440-XCOM) combined with a communication module allows easy integration onto the customer's network. See figure below.

C440 communication modules, wired to the C440-XCOM give C440 control capability via communications. The communication modules offer flexible mounting options (DIN rail or panel) along with four inputs (24 Vdc or 120 Vac) and two outputs as standard.



Advanced Communication—Communication Module

Note

① Customer can wire remote mounted button to reset module (i.e., 22 mm pushbutton, catalog number M22-D-B-GB14-K10).

2

The following information can be viewed using the communication option:

- Motor status—running, stopped, tripped or resetting
- Individual rms phase currents (A, B, C)
- Average of three-phase rms current
- Percent thermal capacity
- Fault codes (only available prior to reset)
- Percent phase unbalance
- Ground fault current and percent
- Overload relay settings—trip class, DIP switch selections, reset selections
- Modbus address (can be set over the network)

Features and Benefits

Ethernet modules

- Single device supports both EtherNet/IP, Modbus TCP
- Internal switch with two Ethernet ports allows linear or ring network configurations
- Embedded web-services for easy configuration and monitoring with Internet Explorer

DeviceNet

- I/O assemblies with the same size and layout as the legacy Advantage (WPONIDNA) and **IT** (DSNAP) Starter platforms for seamless upgrades to C441 technology with no program changes
- Communication uses only one DeviceNet MAC ID

PROFIBUS

- Capable of baud rates up to 12 Mb
- Intuitive configuration with common PROFIBUS tools

Modbus

- Modbus address and baud rate can be changed easily with C441's user interface (C441M only)

Terminals

- Unique locking mechanism provides easy removal of terminal block with field wiring installed
- Marked terminals for ease of wiring and troubleshooting

On-board I/O assemblies

- Modules offer 4 IN / 2 OUT of network programmable I/O
- 24 Vdc or 120 Vac signal options
- Optical isolation protects the I/O and communication circuits from possible damage due to transients and ground loops
- Inputs feature user-definable debounce, which limits the effects of transients and electrical noise
- Outputs feature a user-definable state for loss of communication: hold last state, ON or OFF

Communication Accessories

Communication modules mount on their own to be used as stand-alone network based I/O or be wired to the C440-XCOM. Parts are available for purchase individually (see "consists of" below) or as part of a kit for C440 communications.

Description	Catalog Number
Expansion Module	
Expansion Module	
Expansion module (Remote Reset/Modbus RTU, RS-485 Communication)	C440-XCOM
Ethernet with I/O Module	
Communication Modules	
DeviceNet communication module kit—120 V I/O (consists of C440-XCOM + C441KS)	C440-DN-120
DeviceNet communication module kit—24 Vdc I/O (consists of C440-XCOM + C441LS)	C440-DN-24
PROFIBUS communication module kit—120 V I/O (consists of C440-XCOM + C441SS)	C440-DP-120
PROFIBUS communication module kit—24 V I/O (consists of C440-XCOM + C441QS)	C440-DP-24
Modbus communication module kit—120 V I/O (consists of C440-XCOM + C441NS)	C440-MOD-120
Modbus communication module kit—24 Vdc I/O (consists of C440-XCOM + C441PS)	C440-MOD-24
Modbus TCP/Ethernet IP communication module kit—120 V I/O (consists of C440-XCOM + C441U)	C440-ET-120
Modbus TCP/Ethernet IP communication module kit—24 V I/O (consists of C440-XCOM + C441V)	C440-ET-24



Technical Data and Specifications**Electronic Overload Relays up to 1500A**

Description	Specification		
	45 mm	55 mm	110 mm
Electrical Ratings	Range	Range	Range
Operating voltage (three-phase) and frequency	690 Vac (60/50 Hz)	690 Vac (60/50 Hz)	690 Vac (60/50 Hz)
FLA Range			
	0.33–1.65A 1–5A 4–20A 9–45A	20–100A	28–140A (NEMA) 35–175A (IEC)
Use with Contactors			
Space-Savings NEMA Size	0, 1, 2	2, 3	4
Trip Class			
	10A, 10, 20, 30 Selectable	10A, 10, 20, 30 Selectable	10A, 10, 20, 30 Selectable
Motor Protection			
Thermal overload setting	1.05 x FLA: does not trip 1.15 x FLA: overload trip	1.05 x FLA: does not trip 1.15 x FLA: overload trip	1.05 x FLA: does not trip 1.15 x FLA: overload trip
Feature	Range	Range	Range
Phase loss	Fixed threshold 50%	Fixed threshold 50%	Fixed threshold 50%
Phase unbalance (selectable: enable/disable)	Fixed threshold 50%	Fixed threshold 50%	Fixed threshold 50%
Ground fault (selectable: enable/disable)	50% of FLA dial setting >150% = 2 sec >250% = 1 sec	50% of FLA dial setting >150% = 2 sec >250% = 1 sec	50% of FLA dial setting >150% = 2 sec >250% = 1 sec
Reset	Manual/automatic	Manual/automatic	Manual/automatic
Indicators			
Trip status	Orange flag	Orange flag	Orange flag
Mode LED	One flash: Overload operating properly Two flashes: Current is above FLA dial setting—pending trip	One flash: Overload operating properly Two flashes: Current is above FLA dial setting—pending trip	One flash: Overload operating properly Two flashes: Current is above FLA dial setting—pending trip
Options			
Remote reset	Yes	Yes	Yes
Reset bar	Yes	Yes	Yes
Communication expansion module	Yes	Yes	Yes
Communication adapter	Yes	Yes	Yes
Capacity			
Load terminals			
Terminal capacity	12–10 AWG (4–6 mm ²) 8–6 AWG (6–16 mm ²)	6–1 AWG (16–50 mm ²)	8–4/0 AWG (10–95 mm ²)
Tightening torque	20–25 lb-in (2.3–2.8 Nm) 25–30 lb-in (2.8–3.4 Nm)	25–30 lb-in (2.8–3.4 Nm)	124 lb-in (14 Nm)
Input, auxiliary contact and remote reset terminals			
Terminal capacity	2 x (18–12) AWG	2 x (18–12) AWG	2 x (18–12) AWG
Tightening torque	7–11 lb-in (0.8–1.2 Nm)	7–11 lb-in (0.8–1.2 Nm)	7–11 lb-in (0.8–1.2 Nm)
Voltages			
Insulation voltage U _i (three-phase)	690 Vac	690 Vac	690 Vac
Insulation voltage U _i (control)	500 Vac	500 Vac	500 Vac
Rated impulse withstand voltage	6000 Vac	6000 Vac	6000 Vac
Overvoltage category/pollution degree	III/3	III/3	III/3

Electronic Overload Relays up to 1500A, continued

Description	Specification		
	45 mm	55 mm	110 mm
Auxiliary and Control Circuit Ratings			
Conventional thermal continuous current	5A	5A	5A
Rated operational current—IEC AC-15			
Make contact (1800 VA)			
120V	15A	15A	15A
240V	15A	15A	15A
415V	0.5A	0.5A	0.5A
500V	0.5A	0.5A	0.5A
Break contact (180 VA)			
120V	1.5A	1.5A	1.5A
240V	1.5A	1.5A	1.5A
415V	0.9A	0.9A	0.9A
500V	0.8A	0.8A	0.8A
IEC DC-13 (L/R F 15 ms1)			
0–250V	1.0A	1.0A	1.0A
Rated operational current—UL B600			
Make contact (3600 VA)			
120V	30A	30A	30A
240V	15A	15A	15A
480V	7.5A	7.5A	7.5A
600V	6A	6A	6A
Break contact (360 VA)			
120V	3A	3A	3A
240V	1.5A	1.5A	1.5A
480V	0.75A	0.75A	0.75A
600V	0.6A	0.6A	0.6A
R300—Vdc ratings (28 VA)			
0–120V	0.22A	0.22A	0.22A
250V	0.11A	0.11A	0.11A
Short-Circuit Rating without Welding			
Maximum fuse	6A gG/gL	6A gG/gL	6A gG/gL
Environmental Ratings			
Ambient temperature (operating)	–13° to 149°F (–25° to 65°C)	–13° to 149°F (–25° to 65°C)	–13° to 149°F (–25° to 65°C)
Ambient temperature (storage)	–40° to 185°F (–40° to 85°C)	–40° to 185°F (–40° to 85°C)	–40° to 185°F (–40° to 85°C)
Operating humidity UL 991 (H3)	5% to 95% noncondensing	5% to 95% noncondensing	5% to 95% noncondensing
Altitude (no derating) NEMA ICS1	2000m	2000m	2000m
Shock (IEC 600068-2-27)	15g any direction	15g any direction	15g any direction
Vibration (IEC 60068-2-6)	3g any direction	3g any direction	3g any direction
Pollution degree per IEC 60947-4-1	3 for product (2 for pcb)	3 for product (2 for pcb)	3 for product (2 for pcb)
Ingress protection	IP20	IP20	IP20
Protection against direct contact when actuated from front (IEC 536)	Finger- and back-of-hand proof	Finger- and back-of-hand proof	Finger- and back-of-hand proof
Mounting position	Any	Any	Any
Climatic proofing	Damp heat, constant to IEC 60068-2-30	Damp heat, constant to IEC 60068-2-30	Damp heat, constant to IEC 60068-2-30

Electronic Overload Relays up to 1500A, continued

Description	Specification		
	45 mm	55 mm	110 mm
Electrical/EMC			
Radiated emissions IEC 60947-4-1-Table 15 EN 55011 (CISPR 11) Group 1, Class A, ISM	30 MHz to 1000 MHz	30 MHz to 1000 MHz	30 MHz to 1000 MHz
Conducted emissions IEC 60947-4-1-Table 14 EN 55011 (CISPR 11) Group 1; Class ISM	0.15 MHz to 30 MHz	0.15 MHz to 30 MHz	0.15 MHz to 30 MHz
ESD immunity IEC 60947-4-1 (Table 13)	±8 kV air, ±6 kV contact	±8 kV air, ±6 kV contact	±8 kV air, ±6 kV contact
Radiated immunity IEC 60947-4-1 IEC 61000-4-3	10 V/m 80 MHz–1000 MHz 3 V/m from 1.4 to 2.7 GHz 80% amplitude modulated 1 kHz sine wave	10 V/m 80 MHz–1000 MHz 3 V/m from 1.4 to 2.7 GHz 80% amplitude modulated 1 kHz sine wave	10 V/m 80 MHz–1000 MHz 3 V/m from 1.4 to 2.7 GHz 80% amplitude modulated 1 kHz sine wave
Conducted immunity IEC 60947-4-1, IEC 61000-4-6	140 dub (10V rms) 150 kHz–100 MHz	140 dub (10V rms) 150 kHz–100 MHz	140 dub (10V rms) 150 kHz–100 MHz
Fast transient immunity IEC 60947-4-1 (Table 13) IEC 61000-4-4	±4 kV using direct method with accessory installed in expansion bay ±2 kV using direct method	±4 kV using direct method with accessory installed in expansion bay ±2 kV using direct method	±4 kV using direct method with accessory installed in expansion bay ±2 kV using direct method
Surge immunity IEC 60947-4-1 (Table 13) IEC 61000-4-5 a Class 4	Three-phase power inputs: ±4 kV line-to-line (DM) ±4 kV line-to-ground (CM) With accessory installed in expansion bay: ±2 kV line-to-line (DM) →1.2/50 us; 2 kV line-to-earth, 1 kV line-to-line ±4 kV line-to-ground (CM)	Three-phase power inputs: ±4 kV line-to-line (DM) ±4 kV line-to-ground (CM) With accessory installed in expansion bay: ±2 kV line-to-line (DM) →1.2/50 us; 2 kV line-to-earth, 1 kV line-to-line ±4 kV line-to-ground (CM)	Three-phase power inputs: ±4 kV line-to-line (DM) ±4 kV line-to-ground (CM) With accessory installed in expansion bay: ±2 kV line-to-line (DM) →1.2/50 us; 2 kV line-to-earth, 1 kV line-to-line ±4 kV line-to-ground (CM)
Power freq. magnetic field immunity IEC 60947-4-1, IEC 61000-4-8	30 A/m, 50 Hz	30 A/m, 50 Hz	30 A/m, 50 Hz
Electromagnetic field IEC 60947-4-1 Table 13, IEC 61000-4-3	10 V/m	10 V/m	10 V/m
Distortion IEEE 519	5% THD max., 5th harmonic 3% max.	5% THD max., 5th harmonic 3% max.	5% THD max., 5th harmonic 3% max.
Electrostatic discharge (ESD) IEC 61000-4-2, EN 61131-2	4 kV contact 8 kV air discharge	4 kV contact 8 kV air discharge	4 kV contact 8 kV air discharge
Electrical fast transient (EFT) IEC 61000-4-4, EN 61131-2	±2 kV using direct method	±2 kV using direct method	±2 kV using direct method
Surge immunity IEC 61000-4-5, EN 61131-2	±2 kV line-to-ground (CM)	±2 kV line-to-ground (CM)	±2 kV line-to-ground (CM)

Communication Modules

2

Description	Modbus	DeviceNet	PROFIBUS	Ethernet
Electrical/EMC				
Radiated emissions IEC 60947-4-1—Table 15, EN 55011 (CISPR 11) Group 1, Class A	30–1000 MHz	30–1000 MHz	30–1000 MHz	30–1000 MHz
Conducted emissions IEC 60947-4-1—Table 14, EN 55011 (CISPR 11) Group 1, Class A	0.15–30 MHz	0.15–30 MHz	0.15–30 MHz	0.15–30 MHz
ESD immunity IEC 60947-4-1 (Table 13)	±8 kV air, ±4 kV contact	±8 kV air, ±4 kV contact	±8 kV air, ±4 kV contact	±8 kV air, ±4 kV contact
Radiated immunity IEC 60947-4-1	10 V/m 80–1000 MHz 80% amplitude modulated 1 kHz sine wave	10 V/m 80–1000 MHz 80% amplitude modulated 1 kHz sine wave	10 V/m 80–1000 MHz 80% amplitude modulated 1 kHz sine wave	10 V/m 80–1000 MHz 80% amplitude modulated 1 kHz sine wave
Conducted immunity IEC 60947-4-1	140 dBuV (10V rms) 150 kHz–80 MHz	140 dBuV (10V rms) 150 kHz–80 MHz	140 dBuV (10V rms) 150 kHz–80 MHz	140 dBuV (10V rms) 150 kHz–80 MHz
Fast transient immunity IEC 60947-4-1 (Table 13) IEC 6100-4-4	±2 kV using direct method	±2 kV supply and control, ±1 kV communication	±2 kV supply and control, ±1 kV communication	±2 kV supply and control, ±1 kV communication
Surge immunity IEC 60947-4-1 (Table 13) IEC 61000-4-5 Class 3	User IO and communication lines ^① : ±1 kV line-to-line (DM) ±2 kV line-to-ground (CM)	User IO and communication lines: ±0.5 kV line-to-line (DM) ±1 kV line-to-ground (CM)	User IO and communication lines: ±0.5 kV line-to-line (DM) ±1 kV line-to-ground (CM)	User IO and communication lines: ±0.5 kV line-to-line (DM) ±1 kV line-to-ground (CM)
Electromagnetic field ^① IEC 60947-4-1 (Table 13) IEC 61000-4-3	10 V/m	10 V/m	10 V/m	10 V/m
Environmental Ratings				
Ambient temperature (operating)	–4° to 122°F (–20° to 50°C)	–13° to 122°F (–25° to 50°C)	–13° to 122°F (–25° to 50°C)	–13° to 122°F (–25° to 50°C)
Ambient temperature (storage)	–40° to 185°F (–40° to 85°C)	–40° to 185°F (–40° to 85°C)	–40° to 185°F (–40° to 85°C)	–40° to 185°F (–40° to 85°C)
Operating humidity	5–95% noncondensing	5–95% noncondensing	5–95% noncondensing	5–95% noncondensing
Altitude (no derating)	2000m	2000m	2000m	2000m
Shock (IEC 60068-2-27)	15G any direction	15G any direction	15G any direction	15G any direction
Vibration (IEC 60068-2-6)	3G any direction	3G any direction	3G any direction	3G any direction
Pollution degree per IEC 60947-1	3	3	3	3
Degree of protection	IP20	IP20	IP20	IP20
Overvoltage category per UL 508	III	III	III	III
DeviceNet				
DeviceNet connections	—	Group 2, polling, bit strobe, explicit, no UCMM	—	Group 2, polling, bit strobe, explicit, no UCMM
DeviceNet baud rate	—	125K, 250K, 500K	—	125K, 250K, 500K
Ethernet				
Ethernet connections	—	—	—	Integrated two-port switch with dual RJ45 Ethernet connections
Ethernet type	—	—	—	Ethernet 10/100 Mbs, AutoMDX, Auto Negotiation
PROFIBUS				
PROFIBUS connections	—	—	Group 2, polling, bit strobe, explicit, no UCMM	—
PROFIBUS baud rate	—	—	9.6K, 19.2K, 45.45K, 93.75K, 187.5K, 500K, 1.5M, 3M, 6M, 12M	—

Note

^① Relates to C441M only.

Communication Modules, continued

Description	Modbus	DeviceNet	PROFIBUS	Ethernet
C441_ 24 Vdc Input				
Nominal input voltage	24 Vdc	24 Vdc	24 Vdc	24 Vdc
Operating voltage	18–30 Vdc	18–30 Vdc	18–30 Vdc	18–30 Vdc
Number of inputs	4	4	4	4
Signal delay	5 ms (programmable to 65 sec)	5 ms (programmable to 65 sec)	5 ms (programmable to 65 sec)	5 ms (programmable to 65 sec)
OFF-state voltage	<6 Vdc	<6 Vdc	<6 Vdc	<6 Vdc
ON-state voltage	>18 Vdc	>18 Vdc	>10 Vdc	>18 Vdc
Nominal input current	5 mA	5 mA	5 mA	5 mA
Isolation	1500V	1500V	1500V	1500V
Terminal screw torque	7–9 in-lb	7–9 in-lb	7–9 in-lb	7–9 in-lb
24V source current	50 mA	50 mA	50 mA	50 mA
Operating Voltage Range—DC Input Modules				
OFF state	0–6 Vdc	0–6 Vdc	0–6 Vdc	0–6 Vdc
Transition region	6–18 Vdc	6–18 Vdc	6–18 Vdc	6–18 Vdc
ON state	18–30 Vdc	18–30 Vdc	18–30 Vdc	18–30 Vdc
C441_ 120 Vac Input				
Nominal input voltage	120 Vac	120 Vac	120 Vac	120 Vac
Operating voltage	80–140 Vac	80–140 Vac	80–140 Vac	80–140 Vac
Number of inputs	4	4	4	4
OFF-state voltage	<30 Vac	<30 Vac	<20 Vac	<30 Vac
ON-state voltage	>80 Vac	>80 Vac	>70 Vac	>80 Vac
Nominal input current	15 mA	15 mA	15 mA	15 mA
Signal delay	1/2 cycle	1/2 cycle	1/2 cycle	1/2 cycle
Isolation	1500V	1500V	1500V	1500V
Terminal screw torque	7–9 in-lb	7–9 in-lb	7–9 in-lb	7–9 in-lb
Operating Voltage Range—AC Input Modules				
OFF state	0–30 Vac	0–30 Vac	0–30 Vac	0–30 Vac
Transition region	30–80 Vac	30–80 Vac	30–80 Vac	30–80 Vac
ON state	80–140 Vac	80–140 Vac	80–140 Vac	80–140 Vac
Output Modules				
Nominal voltage	120 Vac 24 Vdc	120 Vac 24 Vdc	120 Vac 24 Vdc	120 Vac 24 Vdc
Number of outputs	(2) 1NO Form A 1NO/NC Form C	(2) 1NO Form A 1NO/NC Form C	(2) 1NO Form A 1NO/NC Form C	(2) 1NO Form A 1NO/NC Form C
Relay OFF time	3 ms	3 ms	3 ms	3 ms
Relay ON time	7 ms	7 ms	7 ms	7 ms
Max. current per point ^①	5A (B300 rated)	5A (B300 rated)	5A (B300 rated)	5A (B300 rated)
Electrical life	100,000 cycles	100,000 cycles	100,000 cycles	100,000 cycles
Mechanical life	1,000,000 cycles	1,000,000 cycles	1,000,000 cycles	1,000,000 cycles

Note

^① Relates to C441M only.

2.2

NEMA Contactors and Starters

Space-Savings Series

2

Short Circuit Ratings (North America CSA, cUL)

Changes to UL 508A and NEC in recent years have brought a focus to control panel safety with regard to short-circuit current ratings (SCCR). Eaton's XTOE electronic overload relays combined with **XT** Series IEC, Freedom Series NEMA and **XT** NEMA contactors provide a wide variety of SCCR solutions needed for a variety of applications. The SCCR data in this document reflects the latest information as of April 2010.

XTOE Standalone Overload Relays (XTOE)

Overload FLA Range	Maximum Operating Voltage	Standard-Fault Short Circuit Data			High-Fault Short Circuit Data Fuses (RK5, J, CC)			Thermal-Magnetic Circuit Breakers		
		600V (kA)	Maximum Fuse Size (A) (RK5)	Maximum Breaker Size (A)	480V (kA)	600V (kA)	Maximum Fuse Size	480V (kA)	600V (kA)	Maximum Breaker Size
0.33–1.65A	600 Vac	1	6	15	—	—	—	—	—	—
1–5A	600 Vac	5	20	20	100	100	30	100	35	20
4–20A	600 Vac	5	80	80	100	100	100	100	35	80
9–45A	600 Vac	5	175	175	100	100	100	100	35	100/175 (480/600)
20–100A	600 Vac	10	400	400	100	100	200	150	35	250/400 (480/600)
28–140A	600 Vac	10	450	500	100	100	400	100	65	400
35–175A	690 Vac	10	500 (gG)	350 (690 Vac) 320 (415 Vac)	100	100	500 (gG)	100 (415 Vac)	—	350 (LGC3350) 320 (N2MH3)

NEMA Space-Savings Starters with XTOE Electronic Overload Relays

Contactor Frame Size	Overload FLA Range	High-Fault Short Circuit Data Fuses (RK5, J, CC)			Thermal-Magnetic Circuit Breakers		
		480V	600V	Maximum Fuse Size	480V	600V	Maximum Breaker Size
B	1–5A	100	100	30	—	—	—
	4–20A	100	100	30	—	—	—
C	1–5A	100	100	60	—	—	—
	4–20A	100	100	60	—	—	—
	9–45A	100	100	60	—	—	—
D	9–45A	100	100	200	65	35	175
	20–100A	100	100	200	65	35	175
F	20–100A	100	100	200	65	65	350
G	20–100A	100	100	200	65	65	350
	35–175A	100	100	400	65	30	250 (480 Vac) 350 (600 Vac)
H	35–175A	100	100	400	65	30	400

Coil Data—Frames B, C, G

Description	CN13B_ NEMA Size 0	CN13C_ NEMA Size 1	CN13G_ NEMA Size 2
Voltage Tolerance			
Pickup (x U _c)			
AC operated	0.8–1.1	0.8–1.1	0.8–1.1
DC operated	0.7–1.2 ^①	0.7–1.2 ^①	0.7–1.2 ^①
Dropout (x U _c)			
AC operated	0.3–0.6	0.3–0.6	0.3–0.6
DC operated	0.15–0.6	0.15–0.6	0.15–0.6
Power Consumption of the Coil at Cold State and 1.0 x U_c			
AC operated			
Single-voltage coil 50 Hz			
Pickup VA	52	52	149
Pickup W	40	40	80
Sealing VA	7.1	7.1	16
Sealing W	2.1	2.1	4.3
Single-voltage coil 60 Hz			
Pickup VA	67	67	178
Pickup W	50	50	117
Sealing VA	8.7	8.7	19
Sealing W	2.6	2.6	5.3
50/60 Hz			
Pickup VA	62	62	168
	58	58	154
Pickup W	48	48	120
	43	43	43
Sealing VA	9.1	9.1	22
	6.5	6.5	14
Sealing W	2.5	2.5	5.3
	2	2	4.3
DC operated			
Pickup W	12 at 24V	12 at 24V	24 at 24V
Sealing W	0.5 at 24V	0.5 at 24V	0.5 at 24V
Duty factor (%DF)	100	100	100
Switching Time at 100% U_c (Approximate Values)			
Main contact			
AC operated			
Closing delay (ms)	<22	<22	<18
Opening delay (ms)	<14	<14	<13
DC operated			
Closing delay (ms)	<47	<47	<54
Opening delay (ms)	<30	<30	<24
Arcing time (ms)	10	10	10
Electromagnetic Compatibility (EMC)			
Emitted interference	To EN-60947-1	To EN-60947-1	To EN-60947-1
Noise immunity	To EN-60947-1	To EN-60947-1	To EN-60947-1

Note

- ① Coil Suffix TD: U_{min} 24 Vdc/U_{max} 27 Vdc.
 Coil Suffix WD: U_{min} 48 Vdc/U_{max} 60 Vdc.
 Coil Suffix AD: U_{min} 110 Vdc/U_{max} 130 Vdc.
 Coil Suffix BD: U_{min} 200 Vdc/U_{max} 240 Vdc.
 Example:
 U_c = 0.7 x U_{min}—1.2 x U_{max}
 U_c = 0.7 x 24V—1.2 x 27 Vdc

Coil Data—Frames K–M

Description	CN13K_ NEMA Size 3	CN13M_ NEMA Size 4
Voltage Tolerance		
Pickup ($\times U_c$)		
AC operated	0.8–1.1	0.8–1.1
DC operated	0.7–1.2 ^①	0.7–1.2 ^①
Dropout ($\times U_c$)		
AC operated	0.25–0.6	0.25–0.6
DC operated	0.15–0.6	0.15–0.6
Power Consumption of the Coil at Cold State and 1.0 $\times U_c$		
AC operated Single-voltage coil 50 Hz		
Pickup VA	180	180
Pickup W	130	130
Sealing VA	3.1	3.1
Sealing W	2.1	2.1
Single-voltage coil 60 Hz		
Pickup VA	170	170
Pickup W	130	130
Sealing VA	3.1	3.1
Sealing W	2.1	2.1
50/60 Hz		
Pickup VA	170	170
Pickup W	130	130
Sealing VA	3.1	3.1
Sealing W	2.1	2.1
DC operated		
Pickup W	149 at 24V	149 at 24V
Sealing W	2.1 at 24V	2.1 at 24V
Duty factor (%DF)	100	100
Switching Time at 100% U_c (Approximate Values)		
Main contact		
AC operated		
Closing delay (ms)	<33	<33
Opening delay (ms)	<41	<41
DC operated		
Closing delay (ms)	<35	<35
Opening delay (ms)	<30	<30
Arcing time (ms)	15	15
Permissible residual current with actuation of A1–A2 by the electronics (with 0 signal) (mA)	≤ 1	≤ 1
Electromagnetic Compatibility (EMC)		
Emitted interference	To EN60947-1	To EN60947-1
Noise immunity	To EN60947-1	To EN60947-1

Coil Data—Frame S

Description	CN13S_ NEMA Size 5
Voltage Tolerance	
Pickup ($\times U_c$)	$0.7 \times U_{cmin} - 1.15 \times U_{cmax}$
Dropout ($\times U_c$)	$0.2 \times U_{cmin} - 0.6 \times U_{cmax}$
Power Consumption of the Coil at Cold State and 1.0 $\times U_c$	
XTCE185L–XTCEC20R	
Pickup VA	380 ^②
Pickup W	250
Sealing VA	4.3
Sealing W	3.3
Switching Time at 100% Main Contact U_c (Approximate Values)	
XTCE185L–XTCEC20R	
Closing delay (ms)	<80
Opening delay (ms)	<110
Reaction in Threshold and Sealing State Transition Range	
Voltage interruptions	
$(0 - 0.2 \times U_{cmin}) \leq 10$ ms	Time is bridged successfully
$(0 - 0.2 \times U_{cmin}) > 10$ ms	Dropout of the contactor
Voltage dips	
$(0.2 - 0.6 \times U_{cmin}) \leq 12$ ms	Time is bridged successfully
$(0.2 - 0.6 \times U_{cmin}) > 12$ ms	Dropout of the contactor
$(0.6 - 0.7 \times U_{cmin})$	Contactor remains switched on
Excess voltage	
$(1.15 - 1.3 \times U_{cmax})$	Contactor remains switched on
$(> 1.3 \times U_{cmax}) \leq 3$ s	Contactor remains switched on
$(> 1.3 \times U_{cmax}) > 3$ s	Dropout of the contactor
Pickup phase	
$(0 - 0.7 \times U_{cmin})$	Contactor does not switch on
$(0.7 \times U_{cmin} - 1.15 \times U_{cmax})$	Contactor switches on with certainty
$(> 1.15 \times U_{cmax})$	Contactor switches on with certainty

Notes

① At 24V: 0.7–1.3 without additional auxiliary contact modules and ambient temperature +40°C [104°F].

② Control transformer with $U_k \leq 6\%$.

Current Heat Loss (Three-Pole) in Watts

Description	CN13BN0_	CN13CN0_	CN13GN0_	CN13KN0_	CN13MN0_
Current heat loss (three-pole) in watts					
at I_{th}	7.3	12.1	28.8	20.3	30.7
at I_b to AC-3/400V	1.9	6.1	19	15.9	27.0
Impedance per pole, megohms	2	2	1.5	0.4	0.4

Dimensions

Approximate Dimensions in mm [in]

Contactors

Type CN13 NEMA Size 0 and 1

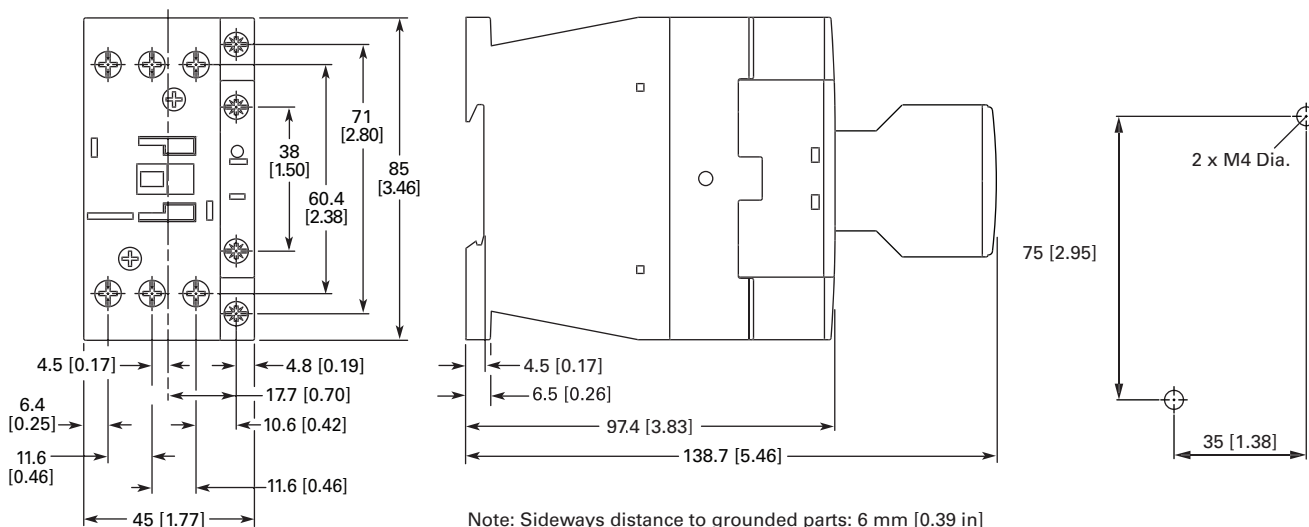

Type CN13 NEMA Size 2

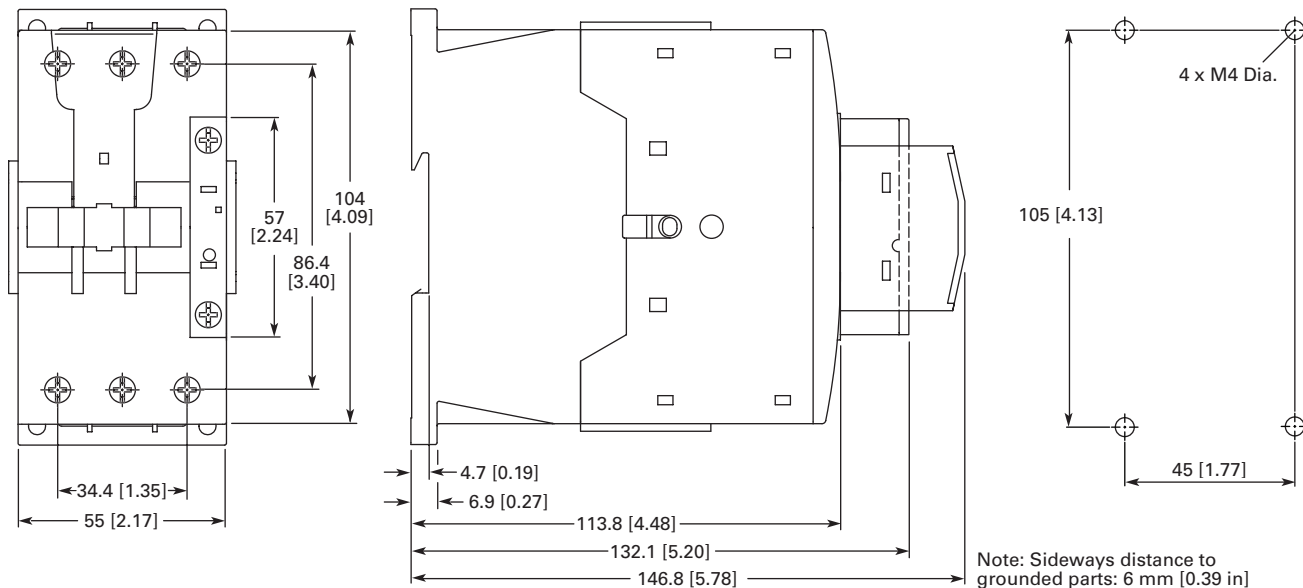

2.2

NEMA Contactors and Starters

Space-Savings Series

Approximate Dimensions in mm [in]

2

Type CN13 NEMA Size 3 and 4

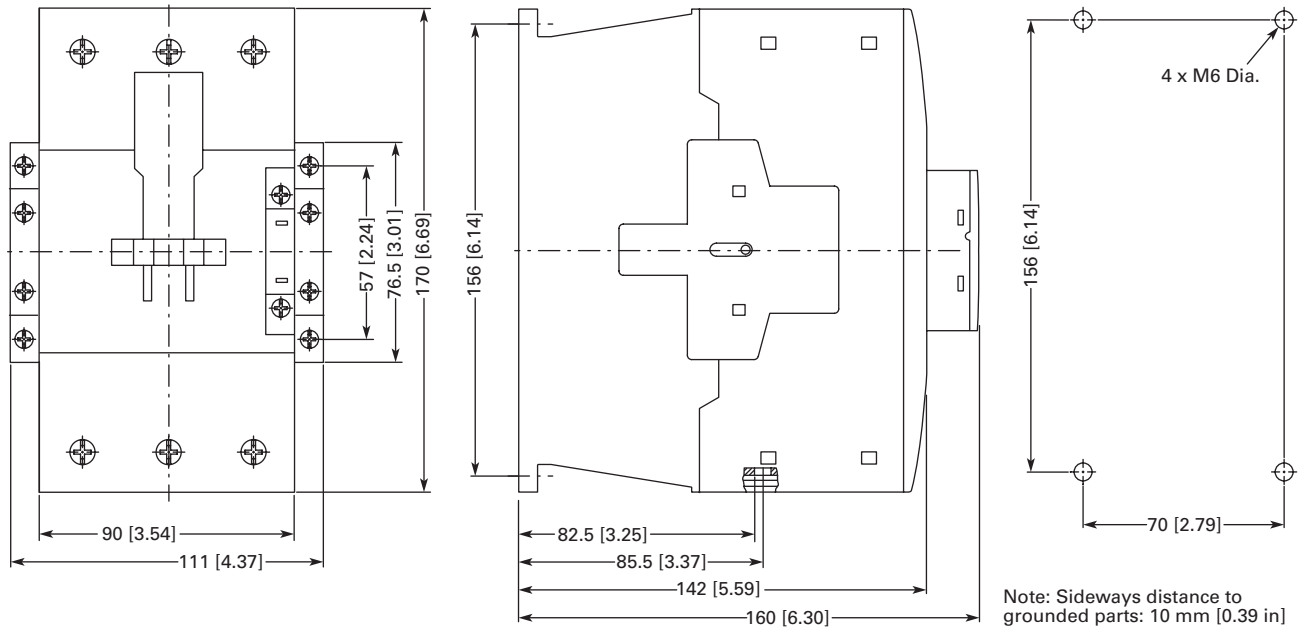

Type CN13 NEMA Size 5

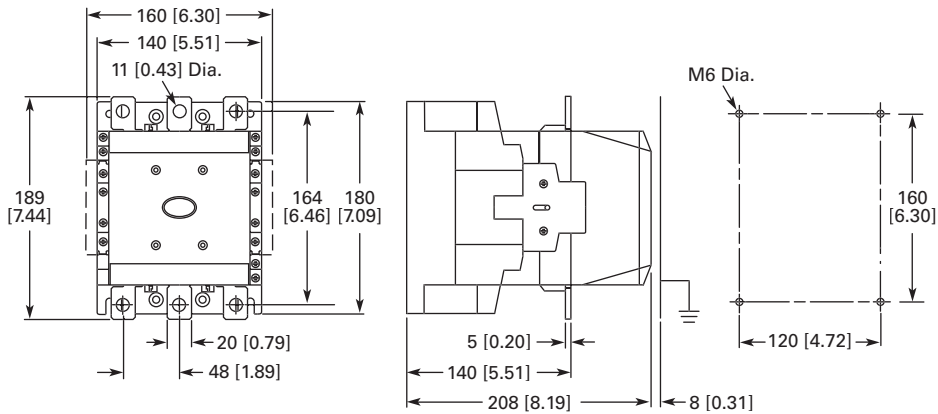

Approximate Dimensions in mm [in]

XTAE Starters with XTOE Overload Relay

Type AN13 NEMA Size 0 and 1

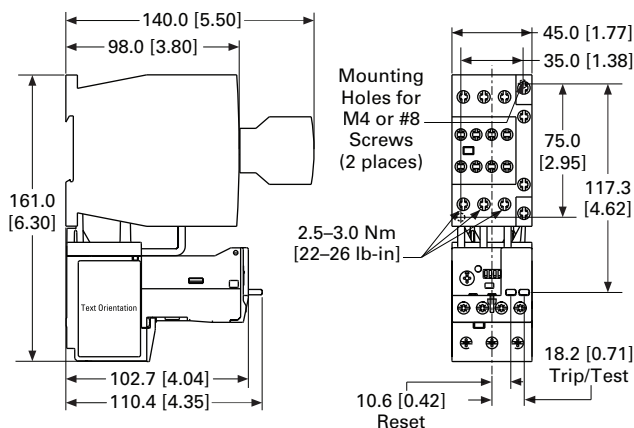

Type AN13 NEMA Size 2

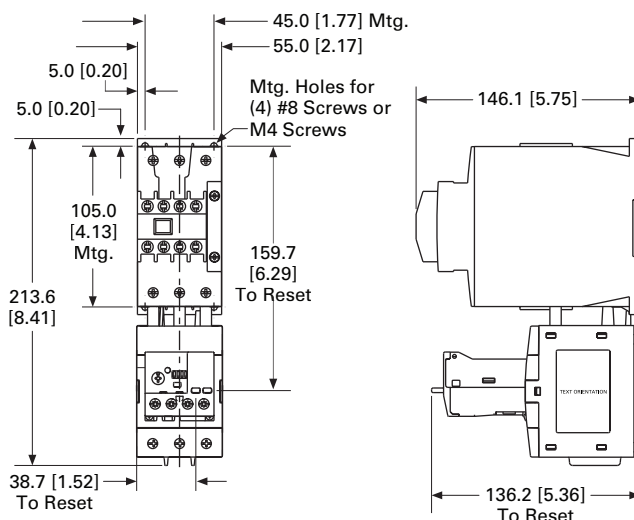

Type AN13 NEMA Size 3

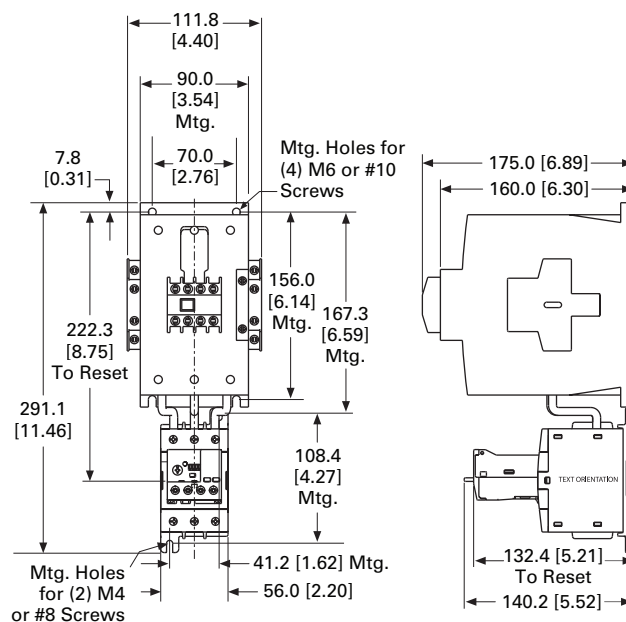

Type AN13 NEMA Size 4

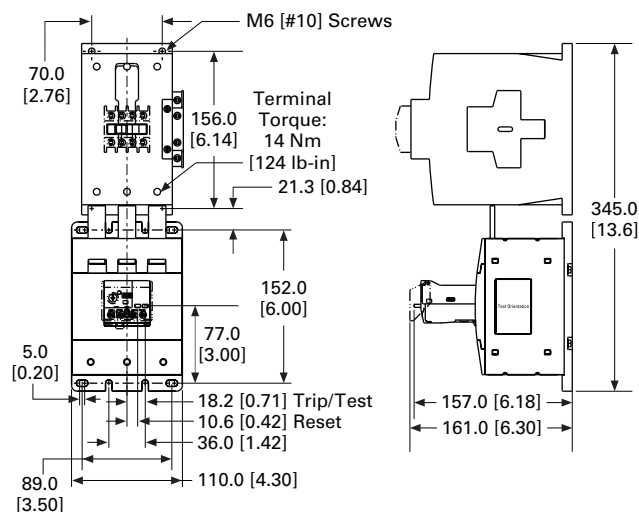

2.2

NEMA Contactors and Starters

Space-Savings Series

Approximate Dimensions in mm [in]

2

Reversing Contactors

Type CN53 Size 0, 1 and 2

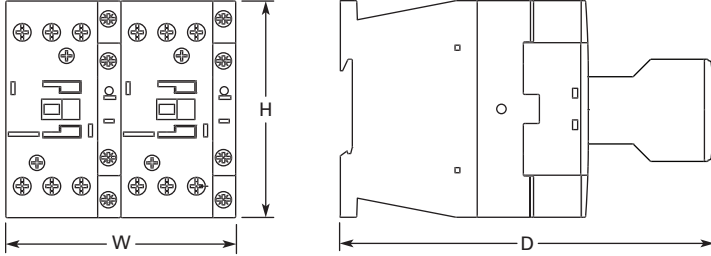

Size 0 and 1

W	H	D
90	85	138
[3.54]	[3.34]	[5.43]

Size 2

W	H	D
110	115	146.8
[4.33]	[4.53]	[5.78]

Type CN53 Size 3 and 4

